

Elektrowerkzeuge  
**Kress**

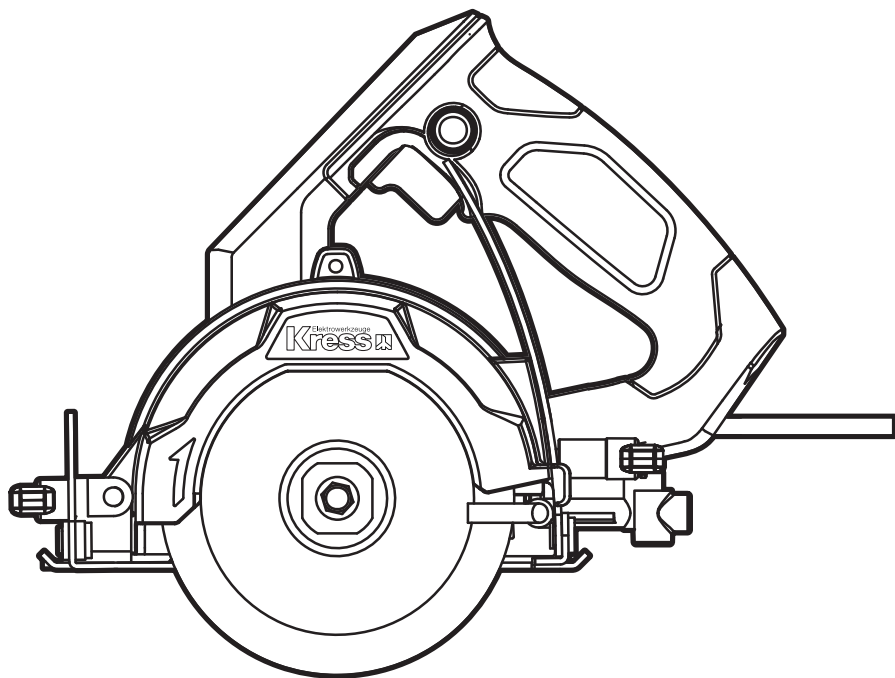

## **SAFETY AND OPERATING MANUAL**

**Portable tile cutter**

**KU076**



# PRODUCT SAFETY

## GENERAL POWER TOOL

### SAFETY WARNINGS

 **WARNING** Read all safety warnings and all instructions. Failure to follow the warnings and instructions may result in electric shock, fire and/or serious injury.

Save all warnings and instructions for future reference.

The term "power tool" in the warnings refers to your mains-operated (corded) power tool or battery-operated (cordless) power tool.

#### 1) Work area safety

a) **Keep work area clean and well lit.** Cluttered or dark areas invite accidents.

b) **Do not operate power tools in explosive atmospheres, such as in the presence of flammable liquids, gases or dust.** Power tools create sparks which may ignite the dust or fumes.

c) **Keep children and bystanders away while operating a power tool.** Distractions can cause you to lose control.

#### 2) Electrical safety

a) **Power tool plugs must match the outlet. Never modify the plug in any way. Do not use any adapter plugs with earthed (grounded) power tools.** Unmodified plugs and matching outlets will reduce risk of electric shock.

b) **Avoid body contact with earthed or grounded surfaces, such as pipes, radiators, ranges and refrigerators.** There is an increased risk of electric shock if your body is earthed or grounded.

c) **Do not expose power tools to rain or wet conditions.** Water entering a power tool will increase the risk of electric shock.

d) **Do not abuse the cord. Never use the cord for carrying, pulling or unplugging the power tool. Keep cord away from heat, oil, sharp edges or moving parts.** Damaged or entangled cords increase the risk of electric shock.

e) **When operating a power tool outdoors, use an extension cord suitable for outdoor use.** Use of a cord suitable for outdoor use reduces the risk of electric shock.

f) **If operating a power tool in a damp location is unavoidable, use a residual current device (RCD) protected supply.** Use of an RCD reduces the risk of electric shock.

#### 3) Personal safety

a) **Stay alert, watch what you are doing and use common sense when operating a power tool. Do not use a power tool while you are tired or under the influence of drugs, alcohol or medication.** A moment of inattention while operating power tools may result

in serious personal injury.

b) **Use personal protective equipment. Always wear eye protection.** Protective equipment such as dust mask, non-skid safety shoes, hard hat, or hearing protection used for appropriate conditions will reduce personal injuries.

c) **Prevent unintentional starting. Ensure the switch is in the off-position before connecting to power source and/or battery pack, picking up or carrying the tool.**

Carrying power tools with your finger on the switch or energising power tools that have the switch on invites accidents.

d) **Remove any adjusting key or wrench before turning the power tool on.** A wrench or a key left attached to a rotating part of the power tool may result in personal injury.

e) **Do not overreach. Keep proper footing and balance at all times.** This enables better control of the power tool in unexpected situations.

f) **Dress properly. Do not wear loose clothing or jewellery. Keep your hair, clothing and gloves away from moving parts.** Loose clothes, jewellery or long hair can be caught in moving parts.

g) **If devices are provided for the connection of dust extraction and collection facilities, ensure these are connected and properly used.** Use of dust collection can reduce dust-related hazards.

#### 4) Power tool use and care

a) **Do not force the power tool. Use the correct power tool for your application.** The correct power tool will do the job better and safer at the rate for which it was designed.

b) **Do not use the power tool if the switch does not turn it on and off.** Any power tool that cannot be controlled with the switch is dangerous and must be repaired.

c) **Disconnect the plug from the power source and/or the battery pack from the power tool before making any adjustments, changing accessories, or storing power tools.** Such preventive safety measures reduce the risk of starting the power tool accidentally.

d) **Store idle power tools out of the reach of children and do not allow persons unfamiliar with the power tool or these instructions to operate the power tool.** Power tools are dangerous in the hands of untrained users.

e) **Maintain power tools. Check for misalignment or binding of moving parts, breakage of parts and any other condition that may affect the power tool's operation. If damaged, have the power tool repaired before use.** Many accidents are caused by poorly maintained power tools.

f) **Keep cutting tools sharp and clean.** Properly maintained cutting tools with sharp cutting edges are less likely to bind and are easier to control.

**g) Use the power tool, accessories and tool bits etc. in accordance with these instructions, taking into account the working conditions and the work to be performed.** Use of the power tool for operations different from those intended could result in a hazardous situation.

**5) Service**

**a) Have your power tool serviced by a qualified repair person using only identical replacement parts.** This will ensure that the safety of the power tool is maintained.

## **SAFETY INSTRUCTIONS FOR ABRASIVE CUTTING- OFF OPERATIONS**

### **Cut-off machine safety warnings**

**1) The guard provided with the tool must be securely attached to the power tool and positioned for maximum safety, so the least amount of wheel is exposed towards the operator. Position yourself and bystanders away from the plane of the rotating wheel.** The guard helps to protect operator from broken wheel fragments and accidental contact with wheel.

**b) Use only diamond cut-off wheels for your power tool.** Just because an accessory can be attached to your power tool, it does not assure safe operation.

**c) The rated speed of the accessory must be at least equal to the maximum speed marked on the power tool.** Accessories running faster than their rated speed can break and fly apart.

**d) Wheels must be used only for recommended applications. For example: do not grind with the side of cut-off wheel.** Abrasive cut-off wheels are intended for peripheral grinding, side forces applied to these wheels may cause them to shatter.

**e) Always use undamaged wheel flanges that are of correct diameter for your selected wheel.** Proper wheel flanges support the wheel thus reducing the possibility of wheel breakage.

**f) Do not use worn down reinforced wheels from larger power tools.** Wheels intended for a larger power tool are not suitable for the higher speed of a smaller tool and may burst.

**g) The outside diameter and the thickness of your accessory must be within the capacity rating of your power tool.** Incorrectly sized accessories cannot be adequately guarded or controlled.

**h) The arbour size of wheels and flanges must properly fit the spindle of the power tool.** Wheels and flanges with arbour holes that do not match the mounting hardware of the power tool

will run out of balance, vibrate excessively and may cause loss of control.

**i) Do not use damaged wheels. Before each use, inspect the wheels for chips and cracks. If power tool or wheel is dropped, inspect for damage or install an undamaged wheel. After inspecting and installing the wheel, position yourself and bystanders away from the plane of the rotating wheel and run the power tool at maximum no load speed for one minute.** Damaged wheels will normally break apart during this test time.

**j) Wear personal protective equipment. Depending on application, use face shield, safety goggles or safety glasses. As appropriate, wear dust mask, hearing protectors, gloves and shop apron capable of stopping small abrasive or workpiece fragments.** The eye protection must be capable of stopping flying debris generated by various operations. The dust mask or respirator must be capable of filtering particles generated by your operation. Prolonged exposure to high intensity noise may cause hearing loss.

**k) Keep bystanders a safe distance away from work area. Anyone entering the work area must wear personal protective equipment.** Fragments of workpiece or of a broken wheel may fly away and cause injury beyond immediate area of operation.

**l) Hold the power tool by insulated gripping surfaces only, when performing an operation where the cutting accessory may contact hidden wiring or its own cord.** Cutting accessory contacting a "live" wire may make exposed metal parts of the power tool "live" and could give the operator an electric shock.

**m) Position the cord clear of the spinning accessory.** If you lose control, the cord may be cut or snagged and your hand or arm may be pulled into the spinning wheel.

**n) Never lay the power tool down until the accessory has come to a complete stop.** The spinning wheel may grab the surface and pull the power tool out of your control.

**o) Do not run the power tool while carrying it at your side.** Accidental contact with the spinning accessory could snag your clothing, pulling the accessory into your body.

**p) Regularly clean the power tool's air vents.** The motor's fan will draw the dust inside the housing and excessive accumulation of powdered metal may cause electrical hazards.

**q) Do not operate the power tool near flammable materials. Sparks could ignite these materials.**

**r) Do not use accessories that require liquid coolants.** Using water or other liquid coolants may result in electrocution or shock.

**s) Recommendation for the use of a residual current device with a tripping current of 30 mA or less.**

# FURTHER SAFETY INSTRUCTIONS FOR ABRASIVE CUTTING-OFF OPERATIONS

## Kickback and related warnings

Kickback is a sudden reaction to a pinched or snagged rotating wheel. Pinching or snagging causes rapid stalling of the rotating wheel which in turn causes the uncontrolled power tool to be forced in the direction opposite of the wheel's rotation at the point of the binding.

For example, if an abrasive wheel is snagged or pinched by the workpiece, the edge of the wheel that is entering into the pinch point can dig into the surface of the material causing the wheel to climb out or kick out. The wheel may either jump toward or away from the operator, depending on direction of the wheel's movement at the point of pinching. Abrasive wheels may also break under these conditions.



Kickback is the result of power tool misuse and/or incorrect operating procedures or conditions and can be avoided by taking proper precautions as given below.

- a) **Maintain a firm grip on the power tool and position your body and arm to allow you to resist kickback forces. Always use auxiliary handle, if provided, for maximum control over kickback or torque reaction during start-up.** *The operator can control torque reactions or kickback forces, if proper precautions are taken.*
- b) **Never place your hand near the rotating accessory.** *Accessory may kickback over your hand.*
- c) **Do not position your body in line with the rotating wheel.** *Kickback will propel the tool in direction opposite to the wheel's movement at the point of snagging.*
- d) **Use special care when working Corners, sharp edges etc. Avoid bouncing and snagging the accessory.** *Corners, sharp edges or bouncing have a tendency to snag the rotating accessory and cause loss of control or kickback.*
- e) **Do not attach a saw chain, woodcarving blade, segmented diamond wheel with a peripheral gap greater than 10 mm or toothed saw blade.** *Such blades create frequent kickback and loss of control.*
- f) **Do not "jam" the wheel or apply excessive pressure. Do not attempt to make an excessive depth of cut.** *Overstressing the wheel increases the loading and susceptibility to twisting or binding of the wheel in the cut and the possibility of kickback or wheel breakage.*
- g) **When wheel is binding or when interrupting a cut for any reason, switch off the power tool and hold the power tool motionless until the wheel Comes to a complete stop. Never attempt to remove the wheel**

**from the cut while the wheel is in motion otherwise kickback may occur.** *Investigate and take corrective action to eliminate the cause of wheel binding.*

- h) **Do not restart the cutting operation in the workpiece. Let the wheel reach full speed and carefully re-enter the cut.** *The wheel may bind, walk up or kickback if the power tool is restarted in the workpiece.*
- i) **Support panels or any oversized workpiece to minimize the risk of wheel pinching and kickback.** *Large workpieces tend to sag under their own weight. Supports must be placed under the workpiece near the line of cut and near the edge of the workpiece on both sides of the wheel.*
- j) **Use extra caution when making a "pocket cut" into existing walls or other blind areas.** *The protruding wheel may cut gas or water pipes, electrical wiring or objects that can cause kickback.*

## SYMBOL

	To reduce the risk of injury, user must read instruction manual
	Double insulation
	Wear ear protection
	Wear eye protection
	Wear dust mask

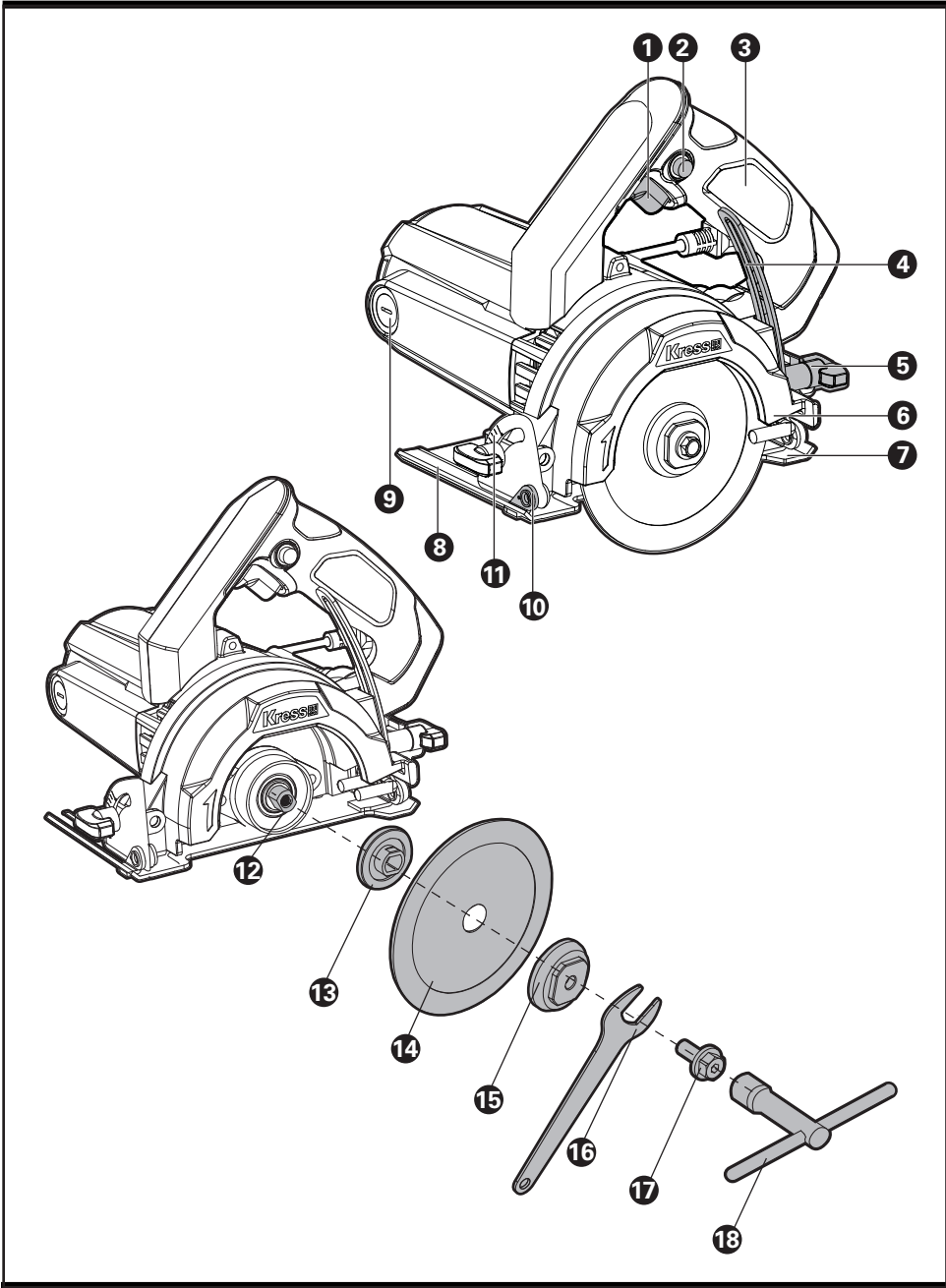

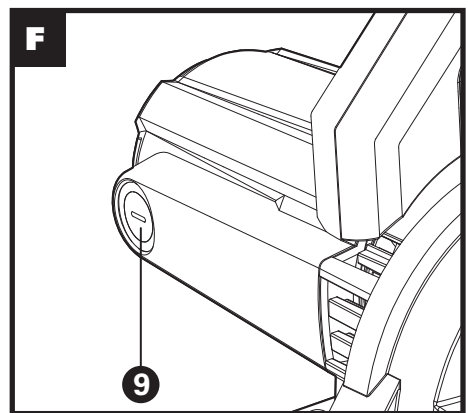
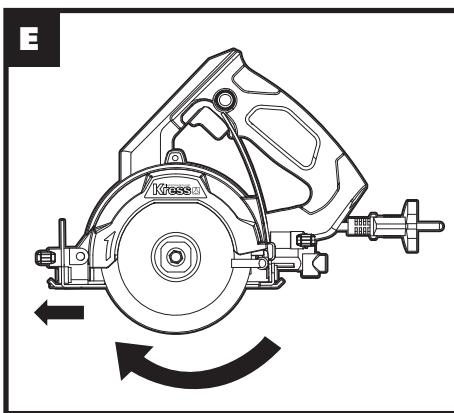
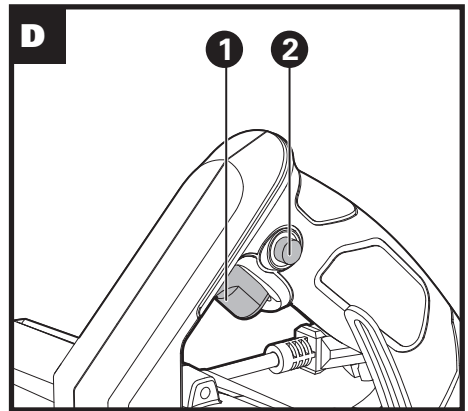
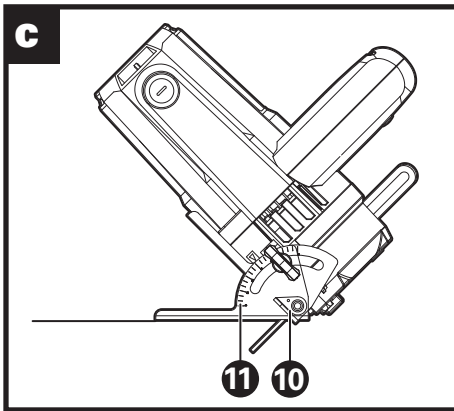
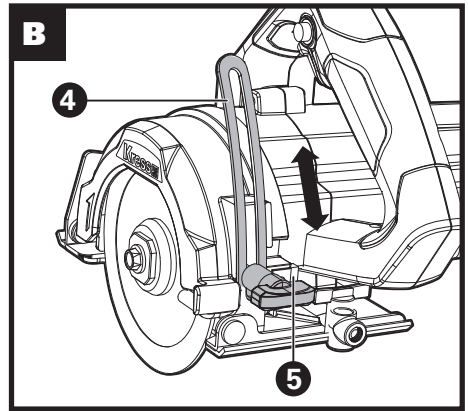
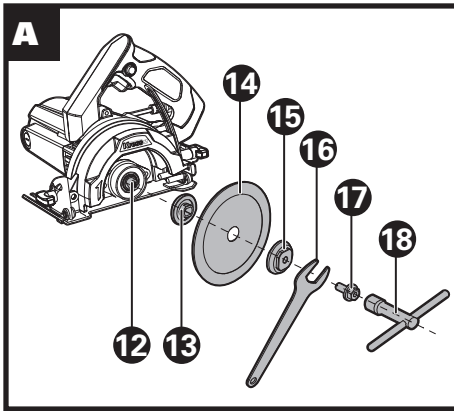

## COMPONENT LIST

1.	On/off switch
2.	Lock-on button
3.	Handle
4.	Depth guide
5.	Depth guide lock wing nut
6.	Protective guard
7.	Baffle
8.	Base plate
9.	Carbon brush cap * 2
10.	Bevel-angle preselection wing bolt
11.	Cutting angle scale
12.	Spindle
13.	Inner flange
14.	Diamond cutting Blade*
15.	Outer flange
16.	Spanner
17.	Blade securing bolt
18.	Socket wrench

\* Not all the accessories illustrated or described are included in standard delivery.

## TECHNICAL DATA

Rated voltage	220-230V~50Hz	
Power input	1400 W	
No load speed	13000 /min	
Spindle thread size	M6	
Blade size	110 mm	
Blade bore	20 mm	
Cutting capacity	90°	32 mm
	45°	21.5 mm
Protection class	□/II	
Machine weight	2.9 kg	

## ACCESSORIES

Spanner	1
Flange	1

We recommend that you purchase your accessories from the same store that sold you the tool. Refer to the accessory packaging for further details. Store personnel can assist you and offer advice.

## OPERATING INSTRUCTIONS



**NOTE:** Before using the tool, read the instruction book carefully.

### INTENDED USE

The machine is intended for the horizontal cutting or slitting of mainly mineral materials such as marble. It should be operated with a protective guard and positioned on a firm base. The machine is intended for wet cutting in specific executions. The machine was not made for cutting wood, plastic or metal.

### 1. FITTING/CHANGING THE DISC (SEE FIG.A)

- Remove the plug from the socket before carrying out any adjustment, servicing or maintenance.
- Wear protective gloves.
- Make sure the diamond-cutting disc has been correctly inserted and is in perfect working condition.

#### 1) FITTING

Place the inner flange onto the spindle. Then place the diamond cutting disc onto the spindle. Tighten the outer flange and the blade securing bolt by using the socket wrench. The assembly of the blade securing bolt must thereby hold the outer flange tightly with the spanner.

**When mounting, make sure** that the direction of the arrows on the protective guard and the diamond cutting disc both point in the same direction.

#### 2) CHANGING

Hold the outer flange with the spanner and loosen the blade securing bolt using a socket wrench in clockwise direction.



**WARNING: Left-hand thread!**

Before reassembly, remove the parts for cleaning.

### 2. ADJUSTING THE CUTTING DEPTH (SEE FIG. B)

To adjust cutting depth, loosen the depth guide lock wing nut and displace the base plate along its front side, lowering or raising it until reaching



the desired measure.

**Raise** ➡ for smaller cutting depths

**Lower** ➡ for greater cutting depths

Use a ruler, scale or something similar to adjust the required depth.

Retighten the depth guide lock wing nut.

Maintain a uniform feeding speed during the entire cutting procedure. If a perfect cut is desired, the diamond cutting disc must protrude 2 mm out of the material.

### 3. ADJUSTING BEVEL CUT (SEE FIG. C)

Loosen the bevel-angle preselection wing bolt (10) for cutting angle setting.

Pivot the machine sideways until the desired cutting angle is set on cutting angle scale (11).

Re-tighten the bevel-angle preselection wing bolt.

### 4. OPERATION

- Clamp down the workpiece if it does not stay in place owing to its own weight.
- Do not load the machine so heavily that it comes to a standstill.
- Caution! Diamond cutting discs become very hot during operation; do not touch them until they have cooled down.

When cutting, do not press, tilt or oscillate.

Gently slide it forward with a speed adapted to the material being worked on.

Do not brake cutting discs that are slowing down to a stop by using side pressure.

#### 1) SWITCHING ON AND OFF (SEE FIG. D)

Depress on/off switch then lock-on button, release on/off switch first then lock-on button.

Your switch is now locked on for continuous use. To switch off your tool, just depress and release on/off switch.

#### 2) CUTTING DIRECTION (SEE FIG. E)

The cutting direction is very important.

The machine must always run counter rotation, so push the machine forwards! Otherwise, the machine may be pressed out of the cut in an uncontrolled fashion.

### 5. CARBON BRUSH REPLACEMENT (SEE FIG. F)

There are two motor brushes which can be easily accessed on the front and back of the motor housing.

Unscrew the carbon brush cap, and remove the carbon brush. If the carbon has worn down to 6mm, it should be replaced. Always replace both brushes at the same time. Insert the new brush and replace the brush cap. Check that the tool is working. Before use, allow it run for a few minutes to enable the brushes to settle. It's advisable to re-lubricate the transmission system every second time you replace your carbon brushes, because grease loses its lubrication properties.

## MAINTENANCE

**Remove the plug from the socket before carrying out any adjustment, servicing or maintenance.**

Your tool requires no additional lubrication or maintenance. There are no user serviceable parts in your power tool. Never use water or chemical cleaners to clean your power tool. Wipe clean with a dry cloth. Always store your power tool in a dry place. Keep the motor ventilation slots clean. Keep all working controls free of dust.

If the supply cord is damaged, it must be replaced by the manufacturer, its service agent or similarly qualified persons in order to avoid a hazard.

## ENVIRONMENTAL PROTECTION



#### Disposal

The machine, its accessories and packaging materials should be sorted for environmentally friendly recycling.

The plastic components are labeled for categorized recycling.





Elektrowerkzeuge  
**Kress** 

Copyright © 2019, Positec. All Rights Reserved.